

انجمن ملی استاندارد ایران
مؤسسه استاندارد و تحقیقات صنعتی ایران

**Plastics pipes and fittings — Equipment for
fusion jointing polyethylene systems —**

**Part 2:
Electrofusion**

*Tubes et raccords en matières plastiques — Appareillage pour
l'assemblage par soudage des systèmes en polyéthylène —*

Partie 2: Électrosoudage



Contents

Page

Foreword.....	iv
1 Scope	1
2 Normative references	1
3 Terms and definitions	2
4 Control unit.....	3
5 Construction requirements.....	4
6 Operating procedures	7
7 Operating requirements	8
8 Mechanical performance.....	11
9 Technical file	11
10 Marking	12
Annex A (normative) Classification scheme.....	13
Annex B (informative) Duty cycle	16
Annex C (normative) Shock resistance test.....	17
Annex D (normative) Vibration test.....	18

Foreword

ISO (the International Organization for Standardization) is a worldwide federation of national standards bodies (ISO member bodies). The work of preparing International Standards is normally carried out through ISO technical committees. Each member body interested in a subject for which a technical committee has been established has the right to be represented on that committee. International organizations, governmental and non-governmental, in liaison with ISO, also take part in the work. ISO collaborates closely with the International Electrotechnical Commission (IEC) on all matters of electrotechnical standardization.

International Standards are drafted in accordance with the rules given in the ISO/IEC Directives, Part 3.

Draft International Standards adopted by the technical committees are circulated to the member bodies for voting. Publication as an International Standard requires approval by at least 75 % of the member bodies casting a vote.

Attention is drawn to the possibility that some of the elements of this part of ISO 12176 may be the subject of patent rights. ISO shall not be held responsible for identifying any or all such patent rights.

International Standard ISO 12176-2 was prepared by Technical Committee ISO/TC 138, *Plastics pipes, fittings and valves for the transport of fluids*, Subcommittee SC 4, *Plastics pipes and fittings for the supply of gaseous fuels*.

ISO 12176 consists of the following parts, under the general title *Plastics pipes and fittings — Equipment for fusion jointing polyethylene systems*:

- *Part 1: Butt fusion*
- *Part 2: Electrofusion*
- *Part 3: Operator's badge*
- *Part 4: Traceability coding*

Annexes A, C and D form a normative part of this part of ISO 12167. Annex B is for information only.

Plastics pipes and fittings — Equipment for fusion jointing polyethylene systems —

Part 2: Electrofusion

1 Scope

This part of ISO 12176 specifies the main performance requirements for electrofusion control units for use with PE electrofusion fittings, conforming to ISO 8085-3, for gas distribution systems. The control units are divided into two input voltage classes: SVLV [safety, very low voltage (0 V to 50 V)] and LV [low voltage (50 V to 240 V)].

This part of ISO 12176 is applicable to electrofusion control units designed for use in the construction of joints between polyethylene (PE) pipes and fittings conforming to ISO standards for gas distribution systems, where the normal operating temperature of the control unit is in the range of $-10\text{ }^{\circ}\text{C}$ to $+40\text{ }^{\circ}\text{C}$. If temperatures outside this range are expected, suitable operating limits will have to be agreed between manufacturer and purchaser.

This part of ISO 12176 is applicable to control units with current or voltage control for fitting systems based on standard resistance wire heating technology.

2 Normative references

The following normative documents contain provisions which, through reference in this text, constitute provisions of this part of ISO 12176. For dated references, subsequent amendments to, or revisions of, any of these publications do not apply. However, parties to agreements based on this part of ISO 12176 are encouraged to investigate the possibility of applying the most recent editions of the normative documents indicated below. Members of ISO and IEC maintain register of currently valid International Standards.

ISO 8085-3:—¹⁾, *Polyethylene fittings for use with polyethylene pipes for the supply of gaseous fuels — Metric series — Specifications — Part 3: Electrofusion fittings.*

ISO/TR 13950:1997, *Plastics pipes and fittings — Automatic recognition systems for electrofusion.*

IEC 60068-2-27:1987, *Environmental testing — Part 2: Tests — Test Ea and guidance: Shock.*

IEC 60529:1989, *Degrees of protection provided by enclosures (IP Code).*

IEC 60742:1983, *Isolating transformers and safety isolating transformers — Requirements, and its Amendment No. 1:1992.*

1) To be published.

3 Terms and definitions

For the purposes of this part of ISO 12176, the following terms and definitions apply:

3.1

operator

competent person entitled to assemble PE gas pipes with electrofusion fittings

3.2

control unit

unit implementing the output fusion parameters of voltage or current and time or energy to execute the fusion cycle as specified by the electrofusion fitting manufacturer

Control units are classified with respect to electrical and process characteristics. Different types of control unit can be defined as follows:

3.2.1

preset control unit

control unit providing a stepped output power, preset by the manufacturer and generated at one or several selectable levels of voltage or current or energy or time

3.2.2

variable control unit

control unit providing a stepped output power generated from variable parameters defined from an external source

EXAMPLE Bar code, magnetic card, microchip

3.2.3

multimode control unit

control unit providing a stepped output power generated at several levels of voltage and current and covering the energy input requirements of fittings from several manufacturers within the specification of each system using at least one preset system associated with one variable system

3.2.4

multipurpose control unit

control unit providing a stepped or continuous output power generated at several levels of either voltage or current

3.2.5

universal control unit

control unit providing a stepped or continuous output power generated at several levels of both voltage and current coming from a variable system

3.3

data retrieval unit

any type of control unit (3.2) allowing the storage of the actual fusion data and permitting a read-out of this data

3.4

automatic control unit

any type of control unit (3.2) with automatic data input or fusion cycle control, where the operator cannot alter the fusion parameters

3.5

control cycle

t
a fixed period of time, composed of an on-load period t_1 and an off-load period t_2

The total time $t = t_1 + t_2$.

3.6 duty cycle

t_d proportion of the control cycle time t for which the output power is on load, t_1 , expressed as a percentage, i.e.

$$t_d = \frac{t_1}{t_1 + t_2} \times 100$$

3.7 output voltage

output voltage value expressed as the RMS (root mean square) value (and not peak value)

3.8 reference output voltage

output voltage value at 75 % of the maximum output voltage of the control unit

3.9 soft start

stepped voltage increases over time periods in the order of seconds

4 Control unit

4.1 Preset control unit

In this type of control unit, the output values of one parameter (voltage, current, energy or time) are fixed.

The fifth code-letter in the designation of this type of control unit is "F" (see A.2.1).

4.2 Variable control unit

In this type of control unit, all the fusion parameters are introduced from an external source (for instance bar code, magnetic card, microchip) programmed by the electrofusion fittings manufacturer.

The fifth code-letter in the designation of this type of control unit is "V" (see A.2.1).

4.3 Multi-mode control unit

In this type of control unit, the output values of one parameter (voltage, current, energy or time) are fixed, but are associated with a variable fusion parameter.

The fifth code-letter in the designation of this type of control unit is "V" (see A.2.1).

4.4 Multipurpose control unit

This type of control unit can be used with electrofusion fittings from more than one manufacturer.

The fifth code-letter in the designation of this type of control unit is "V" (see A.2.1).

4.5 Universal control unit

In this type of control unit, all the fusion parameters are automatically introduced from an external source (for instance bar code, magnetic card, microchip) programmed by the electrofusion fitting manufacturer. The control unit controls both the voltage and the current.

In the designation of this type of control unit, the third code-letter is "W", the fifth code-letter is "V" and the sixth code-letter is "A" (see annex A).

5 Construction requirements

5.1 General

An electrofusion control unit can be a single unit or composed of several separate units. Therefore the control panel and the regulation system may or may not be integrated in a single unit.

Where the control unit is to be connected to a power generator, the manufacturer of the unit shall specify the input power requirements.

A portable control unit, with its frame (if supplied) and any associated input cable of at least 3 m included, shall not be heavier than 35 kg.

The control unit shall not start the fusion cycle if the fusion parameters introduced are out of the specified working range of the control unit.

NOTE It is recommended that:

- the control unit be designed to allow ease of calibration and maintenance;
- the control unit be designed and constructed to allow its safe use in normal field conditions;
- the control unit and its accessories be designed to minimize the risk of corrosion or mechanical damage due to transport and handling in the field, likely to impair the performance of the control unit;
- the control panel (for instance keyboard, display) be protected from impact damage during transport and handling.

5.2 Electrical safety

The control unit shall be protected in accordance with IEC 60529 such that the protection against direct contacts shall be at least to IP5X and the protection against the ingress of moisture shall be in accordance with class IPX4. All printed-circuit boards shall be protected against the effects of condensation. No water shall lodge or accumulate in switches or buttons mounted on the control unit.

The control unit and its accessories shall fulfil the safety requirements of national regulations.

5.3 Cables

5.3.1 General

Input and output cables may be disconnectable or permanently connected. The cables shall remain flexible over the whole range of normal operating and storage conditions (i.e. $-10\text{ }^{\circ}\text{C}$ to $+40\text{ }^{\circ}\text{C}$).

A cable winding or storage facility shall be provided on the control unit.

Cables may require additional screening to satisfy the conditions required for safe operation of portable power supplies (i.e. isolated or earthed systems) and safety features fitted to the control unit.

5.3.2 Input cable

If a permanently attached input cable is provided, its nominal length shall be at least 3 m and a facility for input cable winding, storage and protection during transport shall be fitted to the control unit.

5.3.3 Output cable

The nominal length of the output cable(s) shall be at least 2,5 m.

The output cable(s) shall be suitable for the following functions:

- supply of electrical power to the fitting;
- sensing of the applied voltage and transmission of a feedback signal;
- supply and return of the identification voltage for the fitting verification procedure (resistance sensing).

5.4 Cable connectors

The connectors shall conform to the requirements given in IEC 60529 (see 5.2) for use in outside weather conditions.

They shall have the following features:

- the contact resistance shall be as low as practicable;
- the connectors shall sense the applied voltage;
- the connectors shall allow easy attachment of the cables;
- the design of the connectors shall provide protection against direct human contact when connected to the fitting during the fusion cycle.

5.5 Operator controls

The control unit shall at least have the following operator controls:

- a START button which shall be green;
- a RESET button, operation of which under any fault conditions shall cause a break in the output circuit;
- a STOP switch, which shall be red and operation of which under any fault conditions shall cause a physical break in the input circuit.

An overload protection device shall be fitted to the input side of the control unit.

5.6 Displays

All displays shall be clearly visible both in bright sunlight and in subdued-light conditions.

5.7 Temperature-sensing element for fusion energy compensation

The control unit may be equipped with a temperature-sensing element for measurement of ambient temperature with an accuracy of ± 1 °C. The temperature-sensing lead may be fitted inside the control unit or externally for manual control by the operator. If fitted inside, it shall not be influenced by the heat produced by the control unit.

External temperature-sensing elements shall be protected from mechanical damage.

5.8 Input data decoder

The control unit shall be equipped with a decoder for reading the input data received from a manual keyboard or from an automatic system, for instance using a terminal sensor, bar code, magnetic card.

Control units with an automatic fusion data recognition system as described in ISO/TR 13950 shall be programmed to allow decoding of such data.

It shall not be possible to introduce or modify the input data once the fusion cycle has started.

5.9 Digital-data output connectors

5.9.1 General

The control unit may be equipped with a data retrieval unit which allows retrieval of stored fitting and fusion data. The data retrieval unit shall include the following components:

- a memory for storage of the data;
- an interface for data transmission (communication).

The control unit shall have a routine incorporated to facilitate data downloading.

5.9.2 Memory

The memory may be either an integral or removable part of the unit. The capacity of the memory shall allow a minimum storage of 250 fusion records.

A warning programme may be included to prevent loss of data.

In case of memory overflow, the oldest data shall be deleted.

5.9.3 Interface

Units with data retrieval shall have an interface available to download the data stored in the memory to other electronic devices (for instance personal computer, printer) for analysis and/or display and for storage.

The interface shall be a connector of a standard type (for instance PCMCIA, serial port and/or parallel port), with or without an intermediate remote transmitter/receiver link.

5.9.4 Data protection

Control units with data retrieval shall include the following features to prevent loss of data:

- fusion data shall be recorded continuously during the fusion operation;
- in the event of interruption, the current fusion data shall remain available for control purposes;
- any data retrieval device fitted shall not operate if the memory unit is disconnected.

5.10 Transformers

All transformers shall be safety isolating transformers conforming to IEC 60742.

5.11 Duty cycle

For all control units with a classified output power up to and including 2 kW, the control cycle shall be 10 min. Thus for a 60 % duty cycle (say) t_1 is equal to 6 min and t_2 is equal to 4 min.

For all control units with a classified output power greater than 2 kW, the control cycle shall be 15 min. Thus for a 60 % duty cycle (say) t_1 is equal to 9 min and t_2 is equal to 6 min.

An example of a duty cycle is shown in annex B. The graph is defined by the manufacturer for each control unit between 35 % and 100 % duty cycles at the reference output voltage, as defined in 3.8.

6 Operating procedures

6.1 Supply checks

When the checking system of the control unit verifies that the input voltage and frequency are within the permitted tolerance limits, these checks shall be indicated on a display. When the measured values are outside the tolerance limits, the control unit shall give an audible and/or visual warning signal and a display shall indicate the source of the fault.

6.2 Data input

6.2.1 Manual input

Units with manual data input shall be designed to introduce the process parameter(s) (voltage, current, time and/or energy) as applicable, i.e.:

- one of the parameters for preset control units (see 3.2.1);
- a combination of the parameters for multipurpose and universal control units.

Units with manual data input may be designed with a memory to allow a minimum storage capacity of six combinations of the details of the manufacturer/type/size of fitting; the choice of these combinations is usually based on an agreement between the purchaser and the manufacturer. The data input keyboard may also allow the introduction of the trademark, the type of fitting (for instance socket, saddle or reducer) and the diameter.

6.2.2 Automatic input

Control units provided with a system for automatic data input shall be able to decode data stored in accordance with ISO/TR 13950.

Automatic-input control units shall display the necessary information to permit the operator, if necessary, to check that the displayed information corresponds to the type of fitting being connected.

6.3 Data validation

6.3.1 General

When the input of data is required to start the fusion process, means shall be incorporated to check if the data introduced corresponds to the fitting being connected. This operation shall be done by the operator and/or the control unit.

If the check shows that the data introduced corresponds to the fitting being connected, the data are accepted. If not, the control unit shall not start its fusion programme and shall give a warning signal.

If any single part of the fusion programme introduced cannot be implemented by the control unit, the fusion cycle shall be prevented from starting and the reason shall be displayed.

6.3.2 Data validation by the control unit

The control unit may be equipped with a system which checks the fitting being connected by measuring the resistance of the coil and comparing it with the data introduced, or the control unit may be fitted with another fitting-identification system.

In the case of resistance measurement, the measured value may be displayed for verification purposes. If resistance measurement is used, the calculation shall be based on the resistivity of the coil material (data in the memory of the control unit or data introduced together with the fusion parameters) and the measured ambient temperature.

6.3.3 Data validation by the operator

After displaying control data, the control unit shall require the operator to indicate manually that he has validated the displayed information, either by pressing the "START" button or a separate "ACCEPT" button.

6.4 Fusion cycle

6.4.1 Fusion time and energy

All relevant information concerning time and energy shall be displayed during the fusion cycle.

6.4.2 Incidents during fusion cycle

Any break in the input or output circuit shall require a restart of the complete fusion procedure.

If there is any fault or interruption during the fusion cycle, the control unit shall display the reason in plain text or as an encoded message. Relevant information regarding the fusion cycle may also be displayed.

6.4.3 Optional programmes and equipment

Control units may be provided with specific programmes or equipment introducing obligatory steps which have to be carried out before the fusion cycle can be started, for instance:

- external devices for manual temperature measurement;
- operator identification;
- construction site information.

Control units may also be equipped with complementary programmes which reduce the current peak at the beginning of the fusion cycle. In such cases, the total specified energy shall nevertheless be supplied to the fitting.

7 Operating requirements

7.1 General

The required accuracy of operation shall be maintained at maximum and minimum ambient temperature for at least 12 months without the need for adjustment of the control unit.

7.2 Power supply

The control unit shall be capable of operating satisfactorily from a mains supply or from a generator.

Control units designed for use with portable generators shall, if possible, not be affected by harmonic distortion, inductance and reactance levels of the generator, which might affect its maximum power output.

The input voltage range shall be within $\pm 15\%$ of the nominal value.

The control unit manufacturer shall specify the generator operating-frequency limits, indicating them either on the equipment or in the technical file (see clause 9).

7.3 Coil resistance measurement/electrical-continuity check

For control units fitted with resistance measurement equipment, the accuracy of this equipment shall be within $\pm 5\%$.

The control unit shall check the electrical continuity of the output circuit before allowing the fusion current to be switched on and fed to the fitting. The continuity-checking circuit shall be powered by a voltage which does not significantly heat up the coil but in any case shall not be higher than 24 V.

7.4 Energy output

7.4.1 Energy control

The control unit shall control either the voltage or the current during the fusion cycle as follows to produce the required energy:

a) Voltage control

The output voltage shall be stabilized to within $\pm 1,5\%$ of the nominal voltage value but shall not exceed $\pm 0,5\text{ V}$.

The control unit shall use the voltage at the fitting, or in the transition plug, to control the voltage applied to the fitting.

Voltage-controlled control units may have a design transient-current range of up to 100 A.

Including the progressive voltage increase steps, the required voltage shall be obtained within 1 % of the total fusion time, rounded up to the nearest whole second.

b) Current control

The output current shall be stabilized to within $\pm 1,5\%$ of the nominal current value.

Including the progressive current increase steps or the soft start (see 3.9), the required current shall be obtained in less than 1 % of the total fusion time.

7.4.2 Cycle time

The cycle time shall be controlled to an accuracy of $\pm 1\%$ over the whole range of operating conditions.

7.4.3 Energy control

The total energy supplied to the fitting shall be controlled to an accuracy of $\pm 5\%$ over the whole range of operating conditions and taking into account, if necessary, ambient-temperature compensation.

7.4.4 Power overload

The control unit shall be able to tolerate an overload of 10 % of the nominal power output (see annex A) for at least 1 min.

7.5 Safety devices

7.5.1 General

All safety devices fitted shall remain operational during the complete fusion cycle. They shall interrupt the fusion cycle within the specified time and this shall be indicated on the display and on the data recorder, if present.

7.5.2 Obligatory safety devices

7.5.2.1 Output voltage or current

When the value of the output voltage or current exceeds $\pm 2\%$ of the selected value for more than 5 % of the nominal fusion time, with a maximum of 3 s, the fusion cycle shall be interrupted (not relevant for energy-controlled control units).

7.5.2.2 Break in output circuit

The control unit shall not operate when connected to a resistance above 200 Ω .

NOTE This is for operator safety reasons.

The control unit shall measure the electrical continuity across the voltage-sensing points at the fitting or in the transition plug. The continuity of this circuit shall be continuously monitored during the fusion cycle. If a break (open circuit) occurs in the output circuit, the control unit shall switch off in less than 1 s and a fault condition shall be indicated.

7.5.2.3 Stop switch

The fusion cycle shall be interrupted immediately on activation of the stop switch.

7.5.3 Optional safety devices

7.5.3.1 Input voltage

If the input voltage is outside the permitted limits (see 7.2) for more than 5 s, the fusion cycle shall be interrupted.

7.5.3.2 Frequency

If the frequency of the power supply is outside the permitted limits (see 7.2) for more than 5 s, the fusion cycle shall be interrupted.

7.5.3.3 Short circuit

In the event of a short circuit, the fusion cycle shall be interrupted. Thus any increase in current of, for instance, $> 10\%$ during any 4 s period shall cause the control unit to switch off.

7.6 Counter

The control unit may be equipped with a counter for recording or displaying the total number of fusion cycles.

7.7 Endurance

Following conditioning for 24 h at an ambient temperature of $(23 \pm 2)^\circ\text{C}$, the control unit shall operate for 1 h with a duty cycle of 60 % at $(23 \pm 2)^\circ\text{C}$, based on the duty cycle graph provided by the manufacturer of the control unit.

After testing, the control unit shall still meet the requirements of this part of ISO 12176.

8 Mechanical performance

8.1 Shock resistance test

The control unit with its frame (if supplied) shall be capable of withstanding the shock test given in IEC 60068-2-27 using the following conditions and in accordance with annex C, Figure C.1.

Shock level:	50 g (acceleration)
Pulse duration:	8 ms to 15 ms
Shock wave:	half-sine
Number of shocks:	three per axis along the X, -X, Y, -Y, Z, -Z axes (total 18 shocks)

After testing, the control unit shall still meet the requirements of this part of ISO 12176.

8.2 Vibration test

NOTE This test is under study for further improvement.

The control unit with its frame (if supplied) shall be capable of withstanding a vibration test using the following conditions and in accordance with the figures given in annex D.

Vibration level:	2,186 RMS (average acceleration)
Frequency:	1,25 Hz to 10 Hz, +20 dB/oct 10 Hz to 20 Hz, 0,1 g ² /Hz 20 Hz to 500 Hz, -4,2 dB/oct
Test duration:	10 min per axis (X, Y, Z); see annex D, Figure D.2 (test starts after the maximum level is reached)

After testing, the control unit shall still meet the requirements of this part of ISO 12176.

9 Technical file

The manufacturer shall provide a technical file containing the following information:

- the classification of the control unit (see annex A);
- simulation curves at 24 V output, if relevant, and at the reference output voltage;
- the duty cycle at 100 %, 60 % and 30 %.

The following additional information shall be provided either in the technical file or on the control unit:

- soft start;
- ambient-temperature compensation;
- fitting-temperature compensation;
- fusion data recorder.

10 Marking

The marking on the control unit shall include the following:

- manufacturer's identification;
- type of control unit;
- serial number;
- period of manufacture;
- classification (see annex A);
- input voltage;
- input frequency;
- output power (single value) (see A.1.2).

Annex A (normative)

Classification scheme

NOTE Control units are classified with respect to their electrical and process characteristics. These characteristics are identified by eight code-letters defined in Tables A.1 to A.8.

A.1 Electrical characteristics

A.1.1 Input voltage

Code-letter No. 1: The input voltage is divided into two classes as defined in Table A.1.

Table A.1 — Classification with respect to the nominal input voltage

Code-letter	P ₁	P ₂
Definition	SVLV: Safety, very low voltage (up to 50 V)	LV: Low voltage (between 50 V and 240 V)

A.1.2 Output power

For classification purposes, the output power is defined at the reference voltage for a 60 % duty cycle. A single value shall be marked on the unit.

Code-letter No. 2: The output power is divided into five classes as defined in Table A.2.

Table A.2 — Classification with respect to the output power

Code-letter	1	2	3	4	5
Definition	>0 kW but ≤ 1 kW	> 1 kW but ≤ 2 kW	> 2 kW but ≤ 3 kW	> 3 kW but ≤ 4 kW	> 4 kW but ≤ 5 kW

A.1.3 Control

Code-letter No. 3: The type of control is divided into four classes as defined in Table A.3.

Table A.3 — Classification with respect to the type of output control

Code-letter	U	I	E	W
Definition	Voltage control	Current control	Energy control	Voltage and current control

A.1.4 Output voltage

Code-letter No. 4: The output voltage is divided into three classes as defined in Table A.4.

Table A.4 — Classification with respect to the output voltage

Code-letter	S ₁	S ₂	S ₃
Definition	SVLV: Safety, very low voltage (8 V to 42 V)	VLV: Very low voltage (42 V to 84 V)	LV: Low voltage (84 V to 200 V)

A.2 Process characteristics

A.2.1 Fusion parameters

Code-letter No. 5: The fusion parameters are divided into two types as defined in Table A.5.

Table A.5 — Classification with respect to the fusion parameters

Code-letter	F	V
Definition	Fixed fusion parameters	Variable fusion parameters

A.2.2 Data input

Code-letter No. 6: The methods of data input are divided into two types as defined in Table A.6.

Table A.6 — Classification with respect to the method of data input

Code-letter	K	A
Definition	Manual data input	Automatic data input

A.2.3 Data retrieval

Code-letter No. 7: The inclusion of a data retrieval system is indicated as defined in Table A.7.

Table A.7 — Classification with respect to data retrieval

Code-letter	D
Definition	Equipped with data retrieval system

A.2.4 Number of fitting trade marks

Code-letter No. 8: The number of different fitting trade marks with which the control unit is compatible is indicated as defined in Table A.8.

Table A.8 — Classification with respect to the number of compatible fitting trade marks

Code-letter	M	X
Definition	Single-purpose (one trade mark)	Multipurpose (several trade marks)

A.3 Complete designation

The complete designation of a control unit is as given in Table A.9.

Table A.9 — Complete designation

	Input voltage	Output power	Control	Output voltage	Fusion parameters	Data input	Data retrieval	Number of compatible trade marks
Code-letter (see tables above)	P ₁ or P ₂ See Table A.1	1 or 2 or 3 or 4 or 5 See Table A.2	U or I and/or E or W See Table A.3	S ₁ or S ₂ or S ₃ See Table A.4	F and/or V See Table A.5	K and/or A See Table A.6	D See Table A.7	M or X See Table A.8

A.4 Examples of complete designations

P₂3UES₂VADX: Low voltage input (50 V to 240 V) — 3 kW — Voltage and energy control — Very low voltage output (42 V to 84 V) — Variable fusion parameters — Automatic data input — Data retrieval — Multipurpose

P₁3US₁VADX: Safety, very low voltage input (0 V to 50 V) — 3 kW — Voltage control — Safety, very low voltage output (8 V to 42 V) — Variable fusion parameters — Automatic data input — Data retrieval — Multipurpose

Annex B (informative)

Duty cycle

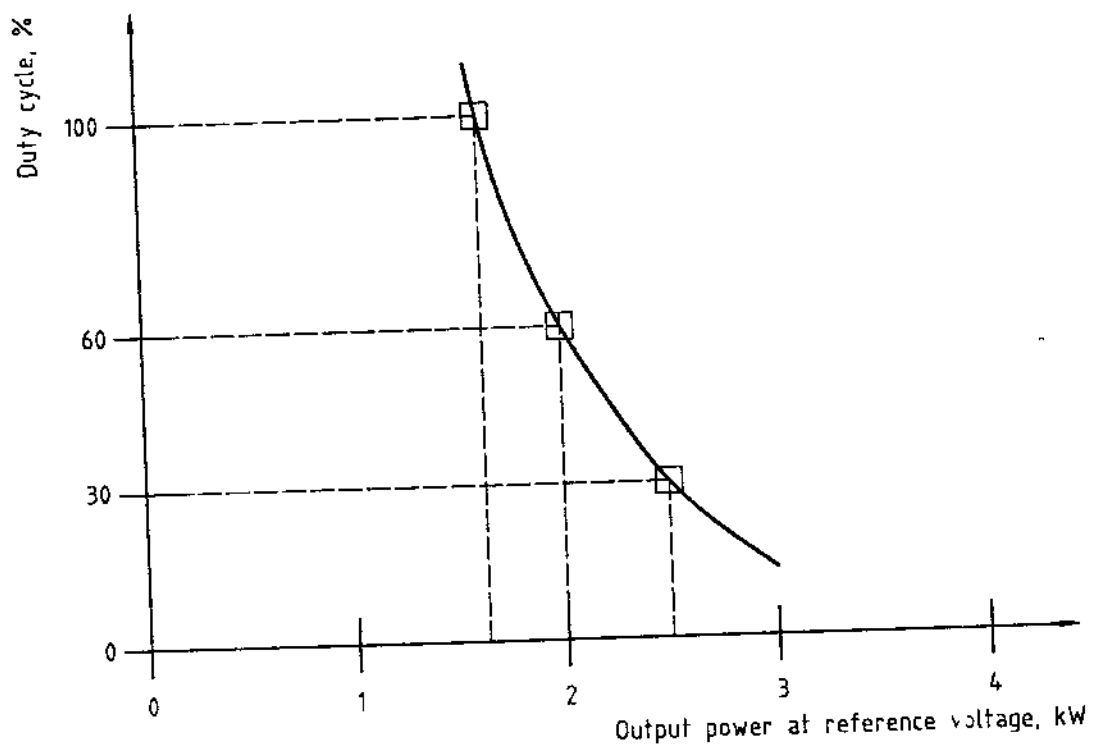
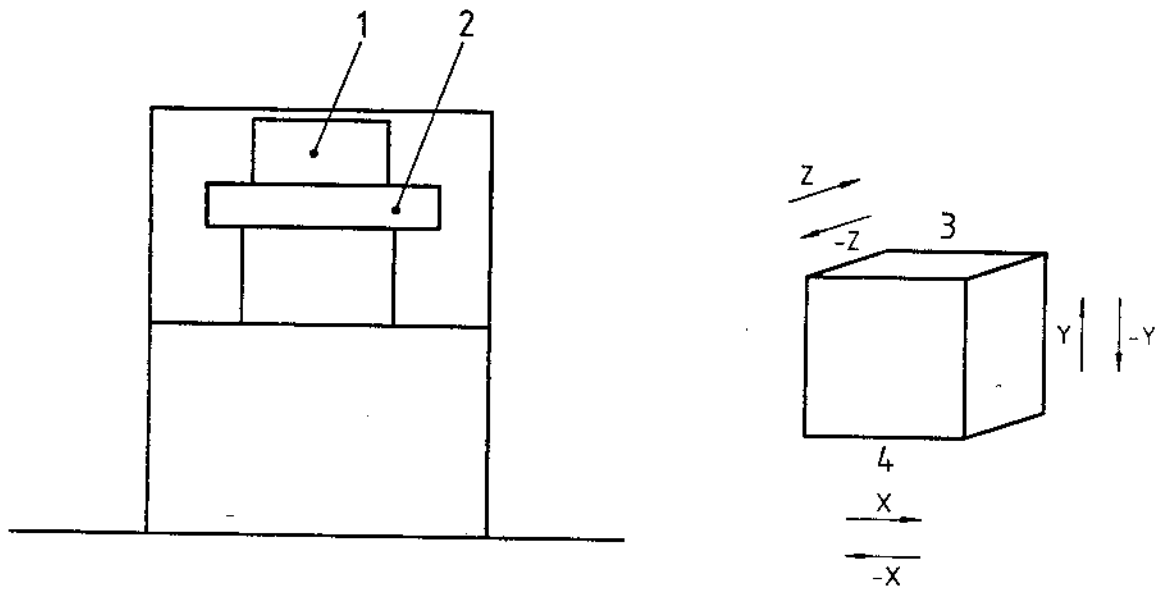

Figure B.1 — Example of duty cycle related to output power at reference voltage

Annex C
(normative)**Shock resistance test****Key**

- 1 Control unit
- 2 Anchorage
- 3 Top
- 4 Bottom

Figure C.1 — Shock test equipment

Annex D
(normative)

Vibration test

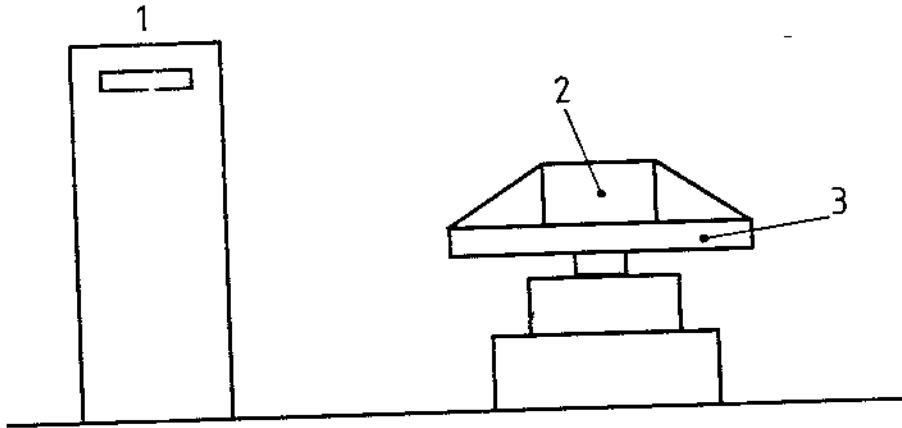

Key

- 1 Generator
- 2 Control unit
- 3 Anchorage

Figure D.1 — Vibration test equipment

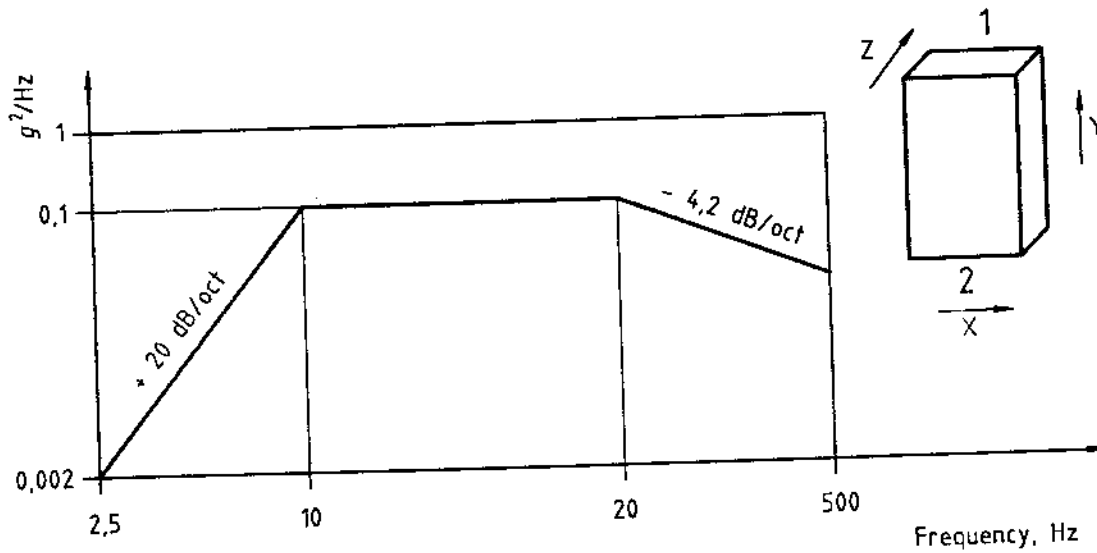

Key

- 1 Top
- 2 Bottom

Figure D.2 — Transport test